

P.C. LAYOUT

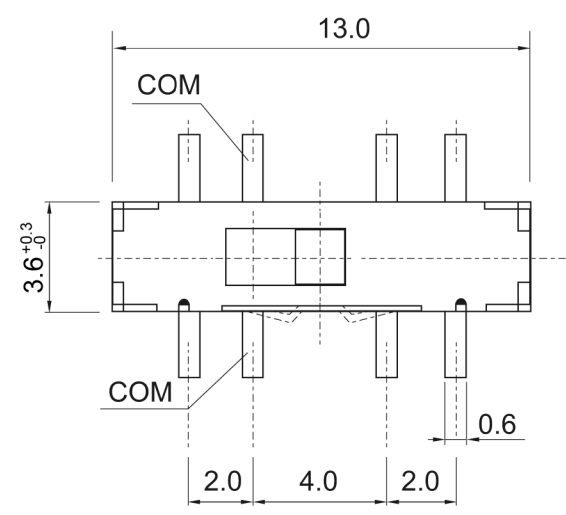

SCHEMATIC

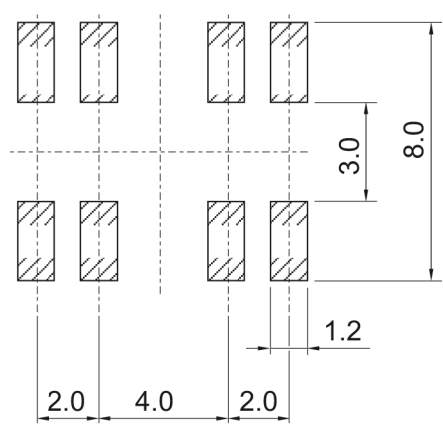
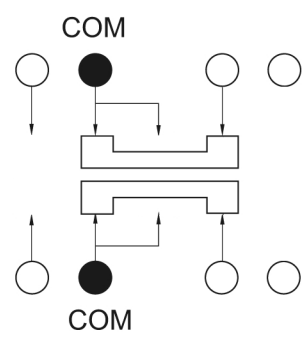

Compliance: RohS II (2011/65/EU)

Tolerances: up to 10: ±0.2mm above 10-50: ±0.3mm above 50-100: ± 0.5mm	Date	Name
	09/07	dr
Material contact plate	07/14	dr
Soldering conditions	07/11	dr
Slider position	06/10	dr
Dimensions	07/09	dr
Material	06/09	dr
Operating temperature	11/07	dr
Material	09/07	dr
Modifications	Date	Name

MMS 228 T

knitter-switch

30 12 35

